

SECONDARY PROPULSION MOTOR INSPECTION DATA

USS	HULL NUMBER	LOCATION (CITY)	DATE (M/D/YYYY)
-----	-------------	-----------------	-----------------

SPM - EXTENDED

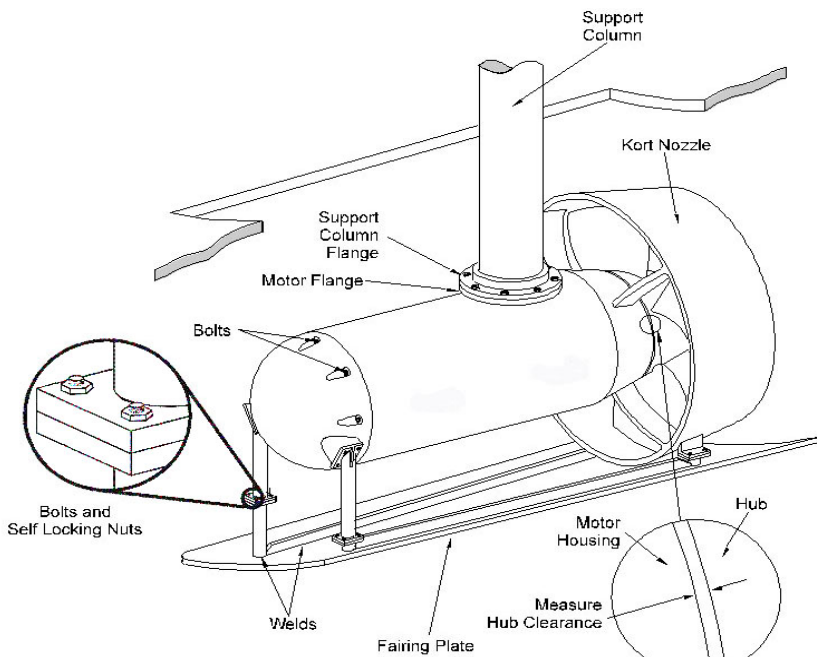

KORT NOZZLE & BLADES

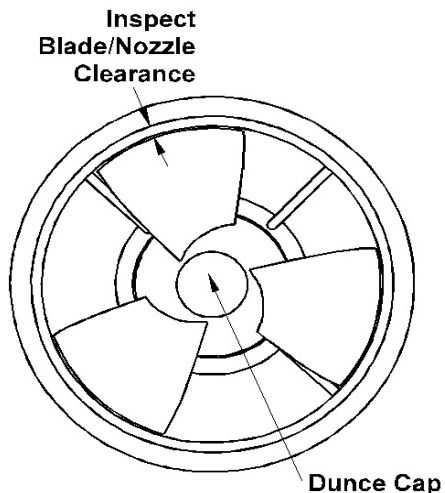

Record Clearance Measurements:

(Pull AFT) - (Push FWD) = Difference

Hub to Motor Housing					
	1	2	3		
Blade Tip to Kort Nozzle					

	FWD		AFT	
	Proj / Dep	a. b.	Proj / Dep	a. b.
Fairing Plate				
Outboard				
Mid Point				
Inboard				

SPM - RETRACTED

Measure Projection and/or Depression (3 Places Forward and 3 Places Aft)

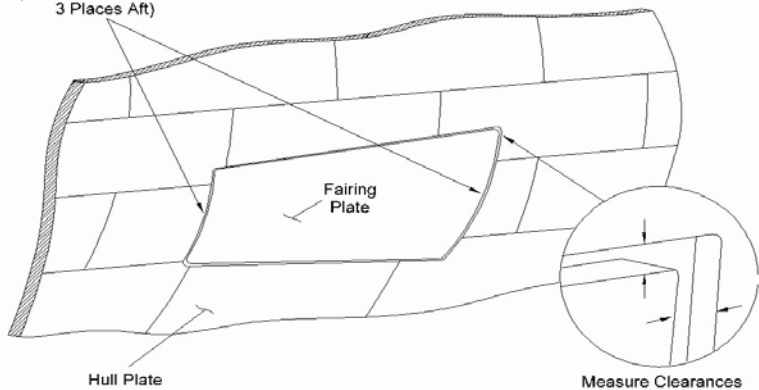

	FR	PDR
Propeller		
Motor Housing		
Support Column		
Fairing Plate		

Condition Summary: